



VS300 TRANSMITTER

PRE-INSTALLATION MANUAL

Document: NHB-VS300-PRE

Issue: 9.0 2018-10-29

Status: Standard

Nautel Limited

10089 Peggy's Cove Road
Hackett's Cove, NS Canada B3Z 3J4
Phone: +1.902.823.3900 or
Toll Free: +1.877.6NAUTEL (6628835) (Canada & USA only)
Fax: +1.902.823.3183

Nautel Inc.

201 Target Industrial Circle
Bangor, Maine USA 04401
Phone: +1.207.947.8200
Fax: +1.207.947.3693

Customer Service (24 hour support)

+1.877.628.8353 (Canada & USA only)
+1.902.823.5100 (International)

Email: support@nautel.com

Web: www.nautel.com

The comparisons and other information provided in this document have been prepared in good faith based on publicly available information. The reader is encouraged to consult the respective manufacturer's most recent published data for verification.

© Copyright 2018 NAUTEL. All rights reserved.

CONTENTS

RELEASE CONTROL RECORD	IX
ABOUT THIS MANUAL	XI
ABOUT SAFETY	XIII
Electrical Hazards	xiii
Lightning Hazards	xiv
RF Hazards	xiv
Toxic Hazards	xiv
Other Hazards	xiv
SAFETY PRECAUTIONS	XV
Personal Safety	xv
Site Safety	xvi
Equipment Safety	xviii
DESCRIPTION	1-1
Capabilities	1-1
Options	1-2
PRE-INSTALLATION TASKS	2-1
Preparing for installation	2-1
Selecting a cabinet for the transmitter	2-3
Installing an antenna feedline	2-3

PHYSICAL REQUIREMENTS	3-1
Dimensions	3-1
Clearances	3-2
Weight	3-2

COOLING REQUIREMENTS	4-1
Air flow in the transmitter	4-1
Cooling	4-2
Heating	4-2

ELECTRICAL REQUIREMENTS	5-1
Electrical power	5-1
Station reference ground	5-3

RF OUTPUT REQUIREMENTS	6-1
Antenna feed line	6-1
Antenna system	6-1

PLANNING PROGRAM INPUTS	7-1
Analog inputs	7-1
Digital inputs	7-3

PLANNING FOR CONTROL AND MONITORING	8-1
Front panel UI control	8-1
Remote inputs	8-2
Remote outputs	8-6
Analog outputs	8-9
Web based AUI control	8-10
External interlock	8-12

PARTS AND TOOLS	9-1
Contacting Nautel	9-1
Parts supplied by Nautel	9-2
Parts not supplied by Nautel	9-2
Parts ordering	9-2
Module replacement program	9-3
Tools for installation	9-3
PRE-INSTALLATION ASSISTANCE	10-1
Pre-installation consulting	10-1
Installation and commissioning service	10-1
Online documentation	10-3
On-site support	10-3
Training	10-3
Extended warranties	10-4
LIST OF TERMS	11-1

RELEASE CONTROL RECORD

Issue	Date	Reason
9.0	2018-10-29	Hardware Release 9 (NARF64H and NARF64H/01). Supports software version VS SW 5.2 and higher.

ABOUT THIS MANUAL

This manual provides information about preparing for the delivery and installation of a VS300 transmitter. This manual is intended for use by field technicians, site managers, and installation planners.

USING THIS MANUAL

Read the task list provided in [Section 2, “Pre-installation tasks” on page 2-1](#). The task list describes the preparations you must make prior to receiving and installing the VS300 transmitter.

Later sections of the manual provide reference information regarding physical, cooling, electrical, and antenna requirements.

TECHNICAL SUPPORT

Nautel offers technical support to customers over the Internet and by telephone. Nautel’s customer support team will answer your questions and work with you to identify and resolve problems.

For 24-hour technical support, call toll free at 1.877.628.8353 (in USA and Canada only) or call 1.902.823.5100 (international) or find us on the Internet at <http://www.nautel.com>.

For parts and tools information, see [“Parts and tools” on page 9-1](#) of the *VS300 Pre-Installation Manual*.

For extended warranty information, see [“Pre-installation assistance” on page 10-1](#) of the *VS300 Pre-Installation Manual*.

VS300 TRANSMITTER MANUALS

The VS300 documentation suite includes the following documents:

VS300 PRE-INSTALLATION MANUAL, VS300-PREINST. Provides instructions and reference information needed when planning and preparing for the installation of a VS300 transmitter.

NAUTEL SITE PROTECTION MANUAL. Provides detailed information about protecting your site from lightning-related hazards.

VS300 INSTALLATION MANUAL, VS300-INST. Provides instructions and reference information needed when installing a VS300 transmitter.

VS300 OPERATING AND MAINTENANCE MANUAL, VS300-OPS-MAINT. Provides instructions for operating, maintaining and troubleshooting a VS300 transmitter. It also provides reference information needed when performing diagnostic procedures.

VS300 TROUBLESHOOTING MANUAL, VS300-TROUBLE. Provides detailed technical information about the VS300 transmitter, including electrical schematics and mechanical drawings.

NAUTEL WEBSITE / ONLINE RESOURCES

The Nautel website provides useful resources to keep you up to date on your VS300. Frequently asked questions (FAQ), 'How To' videos, latest software versions are just a few of the many resources available.

NAUTEL USER GROUP (NUG)

The Nautel Support website allows access to product manuals and the RF Toolkit when you create a free NUG account (see [Figure i on page xiii](#)).

Figure i: Accessing the NUG

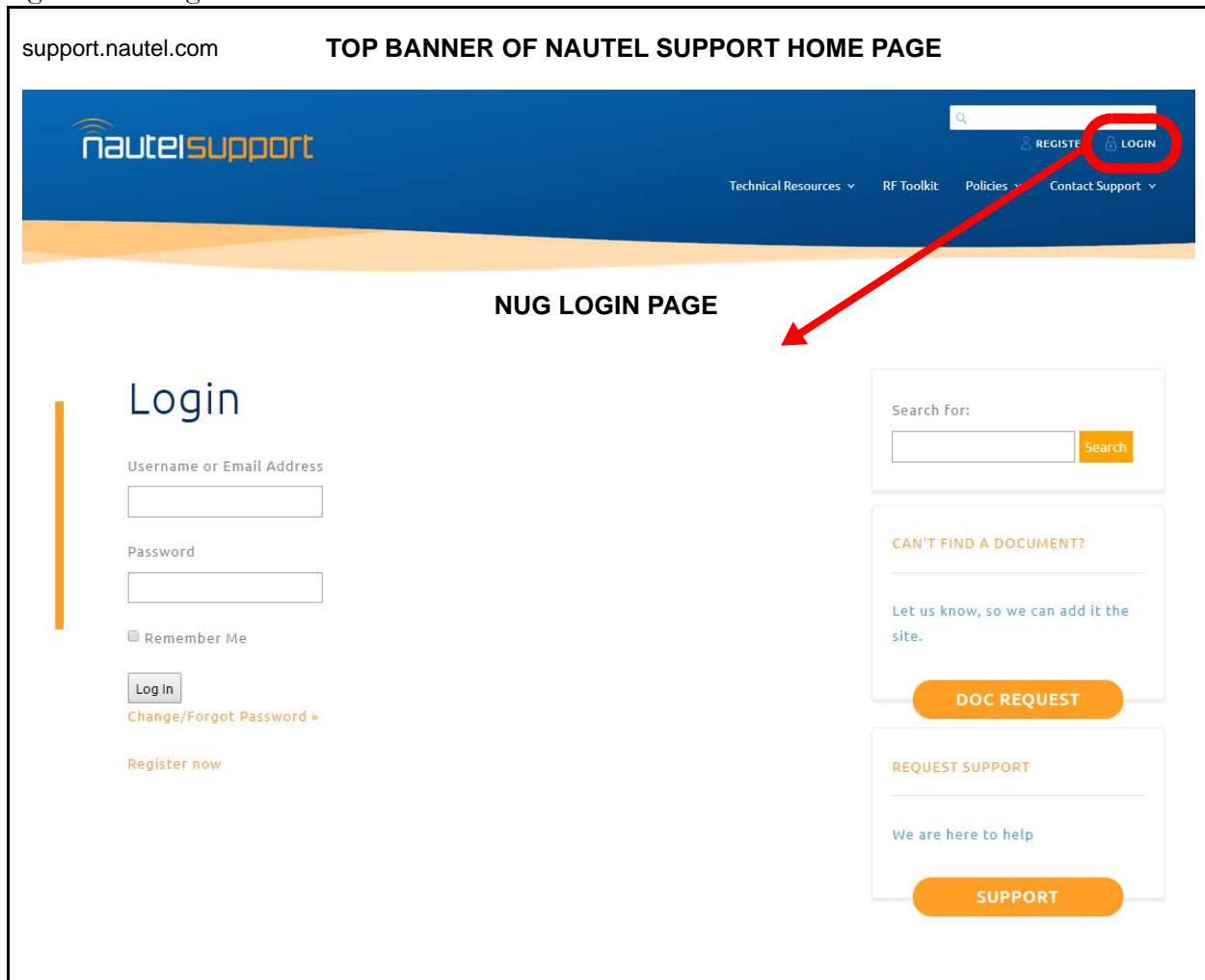

ONLINE DOCUMENTATION

The *Technical Documentation* section of the Nautel Support website provides online access to all the documentation for your VS300. Documentation is provided in Acrobat (PDF) format. You can use the documentation online or print the sections that you need. When using online documents:

- Click on blue text (hyperlinks) to jump to a related section, or to get additional information (e.g., view a term's definition).
- To search a document to find keywords, use **Find** in Acrobat Reader's **Edit** menu.
- To quickly find a specific section, click the section in the PDF file's **Bookmarks** list.

About Safety

All Nautel transmitters are designed to meet the requirements of EN60215, Safety Requirements for Radio Transmitters. The philosophy of EN60215 is that the removal of any cover or panel that can only be opened using a tool is a maintenance activity, and that any person performing a maintenance activity is expected to be trained for that activity. Under EN60215, it is assumed that trained personnel will be knowledgeable and will take precautions such as removing all power to the transmitter before accessing its components.

Electrical Hazards

To remove power from the transmitter, switch off and lock out the ac power. Some transmitter models will have amber LEDs at the bottom rear of the cabinet that glow to remind anyone who has not turned off the power that the system is live and serious danger is present.

DANGER - HIGH VOLTAGE



Indicates dangerous voltage (in excess of 72 volts), capable of causing a fatal electrical shock, are present on or near parts bearing this label.

WARNING: It is not enough to switch off RF power. The power line is still connected. Disconnect and lock out the upstream supply before servicing.

Mount the transmitter ac power disconnect switch/breaker close to the transmitter so that it can be reached quickly in an emergency. Clearly label the switch/breaker (e.g., EMERGENCY SWITCH).

After turning off the power, always perform a measurement to confirm that the power is off before touching anything within the transmitter. If the wrong breaker was opened, the equipment will be live.

WARNING: Do not use an ordinary multimeter to check for voltage, since it may have been left inadvertently on the AMP (A) range, triggering a short and an arc blast that could result in severe burns and even death.

Use only a non-contact voltage probe or a safety voltmeter (available from vendors such as Fluke, Ideal, and Teagam).

Use a proper lockout procedure to ensure that another worker cannot accidentally reapply power while you are performing maintenance on any part of the transmitter or site.

Lightning Hazards

Before opening the transmitter and touching internal parts, remove and solidly ground the antenna connection.

WARNING: It is not enough to ground the antenna terminal with the antenna still connected. Even a small impedance in the ground strap will result in lethal voltages during a lightning strike.

RF Hazards

A serious RF hazard and very high voltages exist in the vicinity of the antenna and its networks during normal operations.

Toxic Hazards

There may be devices used in this equipment containing beryllium oxide ceramic, which is non-hazardous during normal device operation and under normal device failure conditions. These devices are specifically identified with "(BeO)" in the Description column of the Troubleshooting Manual's parts list(s).

Do not cut, crush or grind devices because the resulting dust may be hazardous if inhaled. Unserviceable devices should be disposed of as harmful waste.

Other Hazards

Ensure that appropriate fire alarms and fire extinguishers are available. Extinguishers must be suitable for use on electrical fires.

Many other site safety risks exist. It is beyond the scope of this manual to identify all the risks and procedures.

Safety Precautions

This section provides very important information about protecting the safety of personnel and equipment:

- [Personal Safety](#)
- [Site Safety - see page xvi](#)
- [Equipment Safety - see page xviii](#)

Personal Safety

Training

The training of any personnel who will have physical access to the site or the transmitter is very important. Personnel must be familiar with the transmitter, so that they can avoid physical danger, and be aware of hazards to themselves and the equipment.

Nautel offers a number of training courses covering the basic fundamentals of RF systems and transmitters, and the operation and maintenance of the transmitter. For more information about available courses and schedules, go to the Nautel website at <http://www.nautel.com/Training.aspx>, or ask your Nautel sales representative.

Site Orientation

When you give personnel access to the transmitter site (e.g., hiring new personnel, or giving access keys to personnel), perform a site orientation to ensure that they are familiar with the site, on-site procedures, and on-site hazards. Cover the following topics:

- Securing the site (locking doors and fences) to prevent unauthorized access
- How and when to call for technical support or emergency assistance
- Areas of the site and pieces of equipment that are off limits

Voltage Awareness

Ensure that all personnel that are able to access areas with high voltage circuits or high field strengths are aware of the hazards associated with high voltage. Cover the following topics:

- High voltage or high field strength areas where caution is required
- Physical risks of electric shock
- Risks for personnel with pacemakers or other medical implants
- Induced voltages in high field strength areas
- On-site risks during thunderstorms and lightning strikes
- Operation of safety interlocks (if installed)

First Aid

Nautel does not offer first aid training, since the hazards associated with high voltage and RF energy are not specific to the transmitter. However, the customer should provide first aid training to all personnel who have access to the transmitter site. First aid training should include CPR, care of burns, artificial respiration, and defibrillation if specific equipment is available on-site.

Site Safety

Controlling Access

Transmitters and antennas generate and carry dangerous voltages that can be harmful or fatal. It is very important that you control access to the site and its equipment. To secure your transmitter site, use:

- Locking steel or security doors to prevent casual access
- A perimeter fence to keep trespassers away from the antenna system and feedline
- "No Trespassing" signs
- An alarm system

Marking Hazards

Place warning signs close to any hazardous areas or systems (e.g., the feedline or the antenna system). Make the signs large enough that they cannot be missed. Provide signage in all languages used in the region. These signs are intended not only for authorized personnel, but also for emergency responders or accidental trespassers.

Qualifying Site Personnel

Make sure that personnel who have access to the site are qualified to work around electronics and high voltage systems.

Ac Power Protection

You should take steps to protect equipment from surges (over-voltage spikes) on the ac power lines. Surges may occur during thunderstorms, or because of malfunctions in the electrical distribution grid. Surge suppressors and ac power conditioners can prevent serious damage to your on-site equipment, including the transmitter.

RF Protection

Transmitters and their antenna systems create intense radio frequency fields at the transmitter site, particularly near the feedline, antenna and tower. At some sites, these fields may cause biological effects, including the heating of body tissues. Intense fields can also create dangerous high voltages on ungrounded, conductive surfaces and objects. At certain points where high voltage conductors come close to grounded conductors (e.g., at feedline junctions or on the tower), dangerous electrical arcing or overs can occur. It is very important that you take the following steps to prevent damage to equipment or personnel due to RF fields:

- Use safety interlocks to de-energize transmitters if personnel open doors or panels accessing high field areas
- Place warning signs in any locations where high fields can occur
- Train personnel about the short-term and long-term hazards of RF radiation
- Physically block access to the area around the antenna system, feedline and tower
- Ground all exposed conductive surfaces or objects in high field areas

The RF connection to the transmitter output can be a serious safety hazard. Connect a suitable antenna simulator during installation and commissioning. It is recommended that a switch be used to automatically connect the transmitter to the antenna system without human contact with the transmitting conductors.

Safety Interlocks

The transmitter contains an electrical interlock, which is an external circuit that turns off the RF output if any of its switches are opened.

Ac Disconnect Switch

Safe operation of the transmitter requires an ac disconnect switch. Lock the ac disconnect switch in the disconnected (open) position during the installation process.

Equipment Safety

Electrostatic Protection

The transmitter's systems are very rugged and resistant to damage. However, it is possible for damage to occur because of high voltage electrostatic discharges during servicing. Train all service personnel to ground themselves to bleed off any static charge before opening the transmitter or touching any exposed components. Provide a grounding wand or known ground (e.g., a grounded metal table) that personnel can use to discharge themselves.

Surge Protection

Surge protection is recommended for your entire site. However, even if you do not use a surge protector on the service entrance to the site, you should install a surge protector in the transmitter's ac power feed to prevent over-voltage from entering the transmitter.

Lightning Protection

The transmitter is designed to resist lightning strike damage. However, intense or repeated strikes could damage the transmitter. We recommend that you install lightning suppression on the antenna, tower and feedline to reduce the effect of lightning strikes on the transmitter itself (and to protect the rest of your site equipment and your personnel). For detailed information about lightning protection, see the Nautel Site Preparation Manual, available from your Nautel sales agent, or online from the Nautel website.

Physical Protection

Consider physical hazards to equipment at your site, including the transmitter. Ensure that equipment is protected from weather (e.g., rain or flooding), even during extreme weather events. Place equipment so that it is not in the path of swinging doors or high-traffic areas. Do not allow wheeled items like office chairs or tables with wheels in the transmitter room, as these may damage equipment if accidentally pushed or knocked over. Do not place the transmitter under water pipes, drains, or sprinklers. Keep any equipment that generates heat, like the transmitter, away from flammable materials like ceiling panels, cubicle dividers, and curtains.

Earthquake Protection

If the transmitter site is in a region that experiences any noticeable earthquake activity, take steps to prevent the transmitter from shifting or rocking during an earthquake. Even during minor earthquakes, rocking or movement of the transmitter is likely to damage the feedline connection, and could even cause a catastrophic failure of the ac power feed into the transmitter. During larger earthquakes, the weight of the transmitter chassis could be hazardous to nearby equipment or personnel.

SECTION 1: DESCRIPTION

This section provides a basic description of the VS300 transmitter and includes the following topics:

- [Capabilities](#)
- [Options - see page 1-2](#)

CAPABILITIES

POWER

The VS300 is a solid-state, VHF, frequency modulated broadcast transmitter that is capable of continuous RF output power up to 330 W (in analog mode of operation) into a 1.2:1 VSWR (300 W into a 1.5:1 VSWR).

The operator can vary the power continuously or switch to preset power levels using the VS300 front panel UI or the advanced user interface (AUI). Presets store the power level, frequency and audio input settings.

FREQUENCY

The VS300 is broadband and can operate at any frequency in the FM broadcast band (87.5 - 108 MHz), into a nominal 50 ohm, unbalanced transmission line. This design is ideally suited for all N+1 configurations.

ANTENNA TOLERANCE

The VS300 will operate at rated power with a VSWR of 1.5:1. A higher VSWR results in a protective foldback of output power. The greater the VSWR, the greater the reduction in RF power.

REMOTE CONTROL AND MONITORING

You can monitor all key parameters of VS300 operation, as well as control common functions such as power output and exciter settings, from a remote location.

The VS300 allows for discrete remote control and monitoring using a multiconductor signaling cable, connected between the transmitter and a remote control unit. You can also use a web browser, on any web-interfaced device, to access 100% of the transmitter's local functionality.

AC POWER

The VS300 can operate from a 50/60 Hz, single-phase ac power source at voltages between 90 and 264 V ac. For detailed electrical requirements (e.g., input power, maximum line current, etc.), refer to [Table 5.1](#) in [Section 5](#), “[Electrical requirements](#)”.

OPTIONS

OUTPUT CONNECTOR

The VS300 supports the use of an N-type connector (standard) or a 7/16 DIN connector (optional).

DIGITAL (IBOC) OPERATION

The VS300 can be readily upgraded for hybrid or all-digital (IBOC) operation. Contact Nautel for information on this option.

AUDIO PROCESSOR

The VS300 can be upgraded with an internal audio processor, available from Nautel, which is mounted on pillars directly above the exciter.

SURGE PROTECTION PANEL

Nautel can provide an ac power surge protector panel (Nautel Part # NAX188), to aid in protecting the VS300 from lightning. If purchased, refer to the NAX188 manual for installation details.

SECTION 2: PRE-INSTALLATION TASKS

This section provides a list of tasks that you must perform prior to delivery and installation of the VS300 transmitter.



WARNING: FAILURE TO COMPLY WITH RECOMMENDATIONS MAY VOID YOUR MANUFACTURER'S WARRANTY. FOR MORE INFORMATION, REVIEW YOUR WARRANTY DOCUMENTS.

PREPARING FOR INSTALLATION

To prepare for installation of an VS300 transmitter, perform the following tasks:

1. Ensure that the correct transmitter configuration is ordered. Check the ac power requirements, preset frequency, operating mode(s), and other options.
2. Select a location for the transmitter in the transmitter room. Determine whether additional heating, ventilating or cooling capacity is needed at the site. Identify any special requirements regarding air flow around the cabinet (for example, ducting hot air away from the cabinet, or bringing in external cooling air).
3. If this is an upgrade or replacement transmitter (that is, if the site is already set up for a transmitter), proceed to [Step 7](#). If you are upgrading a site, verify the feedline, the lightning protection systems, and the ac power service.



NOTE:

Be aware of lightning protection issues when installing ac power and RF feedline. Lightning protection is essential to protect both personnel and equipment at your site. Refer to the [Lightning Protection](#) section of Nautel's [Recommendations for Transmitter Site Preparation Manual](#).

4. Install the ac power service into the planned transmitter location, and select a location for the NAX188 ac surge protection panel (if purchased) near the transmitter. Consult with an electrician prior to receiving the transmitter regarding local electrical codes and special considerations based on transmitter power consumption and requirements. For detailed information, see [“Electrical power”](#) on page 5-1.
5. Install lightning protection on the antenna tower.
6. Place a work area with a clear table surface near the transmitter. Provide electrostatic protection measures in the work area.

7. Order any accessories or optional equipment that you may need. Typical requirements include:
 - Tools - soldering iron, screwdrivers, wrenches, etc. (see [Section 9, “Parts and tools” on page 9-1](#)).
 - Test equipment - oscilloscope and digital multimeter.
 - Peripheral equipment - PC or laptop, LAN/network connection, etc.
 - If you are using a network connection (as opposed to a direct connection with a laptop), consult with your network administrator to determine whether the VS300's network feature will be enabled. If so, determine whether DHCP will be used. DHCP allows network IP addresses to be assigned automatically. To use DHCP, you must have a visible DHCP server on your network. If you are not planning to use DHCP (i.e., your network does not have a DHCP server or you are connecting directly to a laptop), you must obtain an IP address and netmask from your network administrator as well as gateway and nameserver(s) as applicable.
8. Terminate the transmitter end of the RF feed line with the appropriate mating connector. Unless otherwise specified in contract documents, the VS300 accepts an N-type connector or a 7/16 DIN connector, depending on the option pre-selected by the customer.
9. Implement a safety interlock, if required.
10. Prepare to integrate the VS300 transmitter into your station control circuitry, if required.
11. Train your station technicians and operators on the use and maintenance of the VS300 transmitter.

SELECTING A CABINET FOR THE TRANSMITTER

To ensure that the cabinet selected for the VS300 transmitter is suitable, perform the following tasks:

1. Ensure that the cabinet in which the transmitter will be installed is able to support the weight of the transmitter. See [“Physical requirements” on page 3-1](#).
 2. Measure the cabinet space to ensure that the transmitter will fit. See [“Physical requirements” on page 3-1](#).
-

INSTALLING AN ANTENNA FEEDLINE

When installing an antenna feedline for the VS300 transmitter, perform the following tasks:

1. Ensure that the RF feedline that will connect the transmitter and the antenna system has a suitably rated coaxial cable.
2. Connect the shield of the antenna feedline coaxial cable directly to the station reference ground where it enters the building. For more information about the station reference ground, see [“Station reference ground” on page 5-3](#).
3. Install lightning protection devices. For more information about lightning protection, refer to the *Lightning Protection* section of Nautel’s *Recommendations for Transmitter Site Preparation Manual*.
4. Pass the center conductor and the shield of the feedline cable through a ferrite toroid that is positioned between the shield ground at the building entrance and the shield termination at the transmitter. Install the ferrite toroid prior to installing flanges on the feedline cable.
 - To obtain the proper size ferrite toroid, contact Nautel support for recommendations (see [“On-site support” on page 10-3](#)), or consult additional, outside suppliers.

SECTION 3: PHYSICAL REQUIREMENTS

This section provides physical specifications for the VS300 transmitter and its components, and lists physical site requirements. This section includes the following topics:

- [Dimensions](#)
- [Clearances - see page 3-2](#)
- [Weight - see page 3-2](#)

DIMENSIONS

The VS300 transmitter (see [Figure 3.1](#)) has the following dimensions:

- Height: 2 RU or 3.5 in (8.9 cm)
- Width: Standard 19 in (48.3 cm) EIA rack mount [min. opening of 17.5 in (44.5 cm)]
- Depth (not including handles) is dependent on RF output connector type:
 - 24.6 in (62.5 cm) for Type 'N'
 - 27.3 in (69.3 cm) for 7/16 DIN (includes bowed front panel)

Figure 3.1: VS300 transmitter

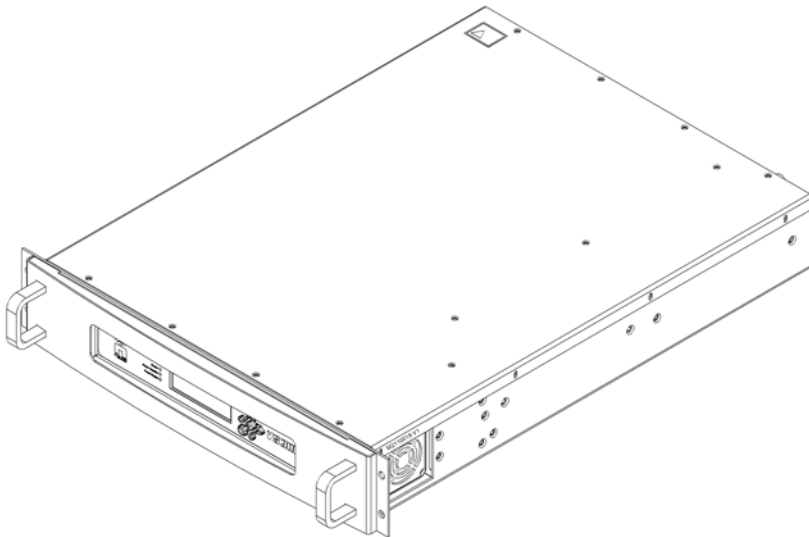

CLEARANCES

Provide a minimum clearance of 61 cm (2 ft.) at the front and back of the VS300. Provide additional clearance for air flow at the sides of the VS300, particularly near the front panel where the primary cooling fan is located.

Check the clearance around the host cabinet to ensure that you will be able to open all doors and access panels. Ensure adequate space is available at the front of the cabinet to allow pulling out the transmitter for servicing fan filters and internal parts/assemblies. Also consider access to the rear of the cabinet for making connections to the transmitter.

Internal fans pull cooling air through air filters in the side of the transmitter. The cooling air exhausts through a grill at the rear of the transmitter.

WEIGHT

The unpacked weight of the VS300 transmitter is 10.4 kg (23 lbs).

SECTION 4: COOLING REQUIREMENTS

This section provides information about heating and cooling requirements for the VS300 transmitter site. Topics in this section include:

- [Air flow in the transmitter](#)
- [Cooling - see page 4-2](#)
- [Heating - see page 4-2](#)

AIR FLOW IN THE TRANSMITTER

See [Figure 4.1](#). The VS300 draws cool (intake) air through air filters in the sides. The air circulates through the switch-mode power supply (on the left), across the low voltage power supply and is exhausted by the PA fan. Warm air exits the transmitter through the grill at the rear. An air exchange rate of 70 CFM achieves acceptable intake/exhaust temperature rise.

Figure 4.1: Air flow in the VS300 transmitter

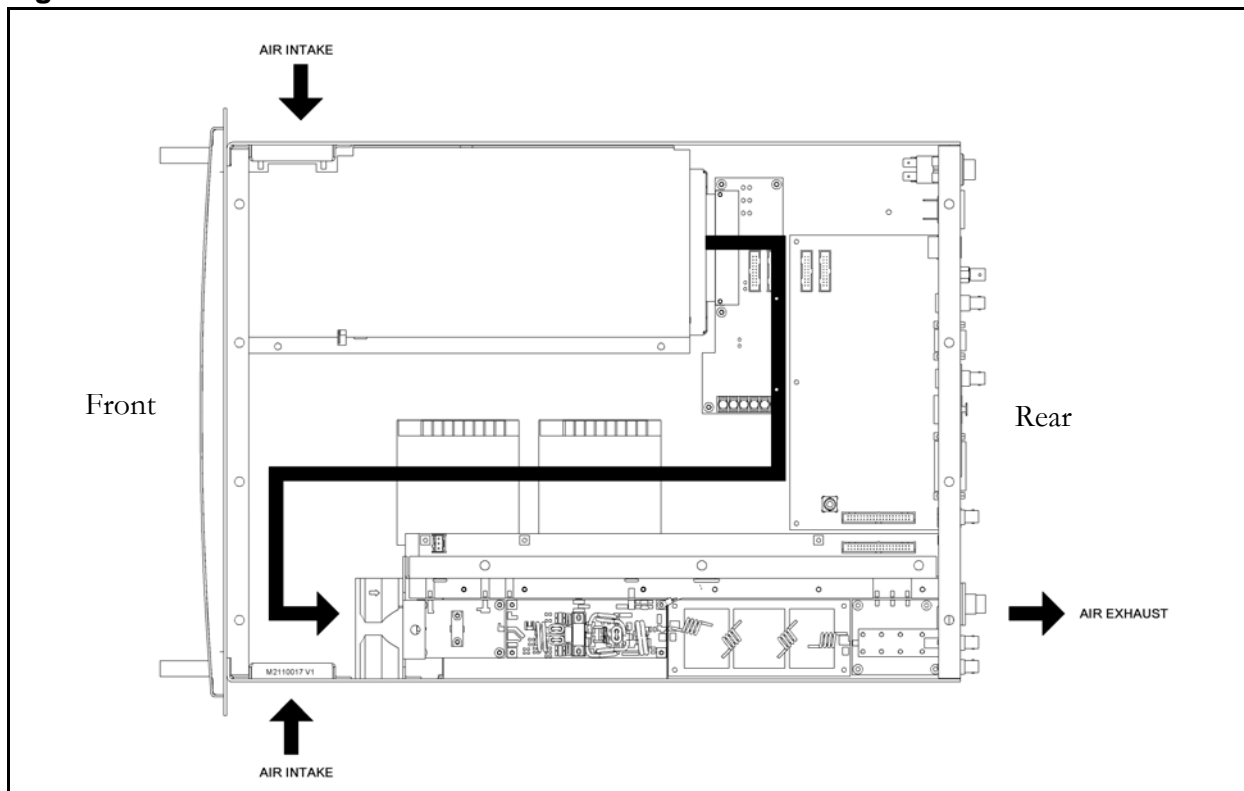

COOLING

Do not allow the transmitter room ambient air temperature to exceed 50°C (122°F) at sea level. Cooler temperatures are recommended in order to improve the reliability of the transmitter. At higher altitudes, derate the maximum inlet air temperature as follows:

- De-rate the ambient temperature 3°C (5.4°F) per 500 m – or 2°C (3.6°F) per 1,000 feet – above sea level.

Example: At 1600 m (1 mile) above sea level, maximum ambient temperature should not exceed 40.4°C (104.7°F).



CAUTION: Ensure that hot air from the transmitter is not drawn back into the transmitter's cool air intake.

COOLING PLANT REQUIREMENTS

Table 4.1: Cooling plant requirements

Mode of operation	Transmitter output (watts)	Worst-case Efficiency (%)	Waste heat (watts)	BTU/hour	Air conditioning required in a closed system (tonnes)
FM	330	58	240	816	0.068

CALCULATING BTU COOLING REQUIREMENTS

To determine the number of British thermal units (Btu) being generated per hour as waste heat, multiply the waste heat (in watts), which is derived from the transmitter output power and its typical efficiency, by 3.413.

HEATING

The transmitter room must contain a heating system that will ensure the ambient air temperature does not drop below 0°C (32°F).

SECTION 5: ELECTRICAL REQUIREMENTS

This section describes electrical power and electrical protection requirements associated with the VS300 transmitter. This section includes the following topics:

- [Electrical power](#)
- [Station reference ground - see page 5-3](#)



CAUTION: Technical pre-commissioning activities described in this section require technical decisions and the customization of electrical circuits. Do not attempt to perform these activities unless you are a certified electrician.

Refer to Nautel's *Recommendations for Transmitter Site Preparation* for information about requirements associated with lightning protection.

ELECTRICAL POWER

The transmitter can operate from a 50/60 Hz 1-phase ac power source, at voltages between 90 and 264 V ac. Ac power enters the transmitter through an IEC 60320 C20 type connector on the rear panel.

VOLTAGE STABILITY

The ac power source's nominal voltage must be stable to within rated limits (see [Table 5.1 on page 5-2](#)) under all loading conditions. The transmitter contains circuitry that maintains the RF output at the preset power level for voltage variations within the specified range.

POWER CONSUMPTION

The input power requirement for the VS300 is 569 VA (for analog mode). Use [Table 5.1 on page 5-2](#) to determine the maximum line current and maximum inrush current values for a given ac supply voltage.

Nautel recommends the ac power source have a 25% over-capacity to ensure adequate regulation.

Table 5.1: VS300 Input power requirements

MODE OF OPERATION	INPUT POWER (VA)	AC SUPPLY (VAC)	TYPICAL LINE CURRENT (A) (LOW LINE)	MAXIMUM INRUSH CURRENT PER LINE (A)
FM (analog)	560	1-Ph, 180 - 264	2.3	12.7
Typical eff. = 62%		1-Ph, 90 - 132	4.7	24.7

Typical line current values are based on maximum RF output power, nominal ac voltage (240 or 120 V ac, as applicable) and typical efficiency.

The maximum inrush current value (per line) is present for half an ac cycle (between 8 and 10 ms). It is more than four times the typical line current and is provided to aid in planning for upstream protection.

Observe local electrical codes when determining wire size and circuit breakers.

Nautel recommends that you base your wire sizes and breaker ratings on the typical line current for analog mode plus a nominal 25%.

AC TRANSIENT POWER PROTECTION

Protect all conductors from the ac power source by connecting bi-directional surge protection devices between each conductor and the station reference ground. Install a ferrite toroid on the ac feed between the transmitter and the bi-directional surge protector. Pass all the conductors and ground, as a group, a minimum of two turns, through a ferrite toroid. Ferrite toroids are provided in the transmitter's Installation kit.

A surge protector panel containing suitably rated varistors is available from Nautel (part # NAX188). Install the surge protector panel close to the station reference ground, and as close as possible to the ac service entrance.

The ac power source usually has the lowest impedance path to ground during a lightning strike and normally carries most of the lightning-induced current away from the transmitter site. When lightning hits the power source (for example, striking a transmission line near the transmitter site), a significant induced current may flow towards the transmitter. The goal of lightning protection is to route the current around the transmitter to the best available ground.

For detailed information about surge protectors and lightning protection, refer to the *Lightning Protection* section of Nautel's *Recommendations for Transmitter Site Preparation Manual*.

STATION REFERENCE GROUND

Install a station reference ground that provides a continuous, low impedance path to the earth.

If a surge protector is not being used, connect the transmitter's designated safety ground point, the shield of the coaxial feedline, and the ground connection of the power source directly to the station reference ground using a low-impedance copper conductor (minimum 3/4" braid, 4-inch strap, or 0 AWG wire). Ensure that the site's ac service entrance ground is directly connected to the station reference ground outside the transmitter building.

If a surge protector is being used, connect the transmitter's designated safety ground point, the shield of the coaxial feedline, and the ground connection of the power source directly to the surge protector, using a low-impedance copper conductor (minimum 3/4" braid, 4-inch strap, or 0 AWG wire). Connect the surge protector to the station reference ground using a similar low-impedance copper conductor.

Ensure that the transmitter site's grounding rods are adequate. For more information about electrical grounding protection, see Nautel's *Recommendations for Transmitter Site Preparation* manual.

SECTION 6: RF OUTPUT REQUIREMENTS

This section describes requirements associated with the antenna and RF cabling to be used with the VS300 transmitter.

For detailed information about protecting the antenna system from lightning strikes, see Nautel's *Recommendations for Transmitter Site Preparation Manual*.

ANTENNA FEED LINE

The antenna feed line interconnecting the transmitter and the antenna system should be a suitably rated coaxial cable. The RF output can be configured to accept a male N-type connection or a male 7/16 DIN connection.

ANTENNA SYSTEM

The antenna system must present $50 \pm j0$ ohms impedance at the carrier frequency. The transmitter will function at rated power while operating into a maximum VSWR of 1.5:1, after which the transmitter begins to fold back the RF output (up to a VSWR of 3:1). Circuitry within the transmitter will prevent damage to the transmitter from high VSWR loads.

SECTION 7: PLANNING PROGRAM INPUTS

The VS300 accepts a variety of analog and digital program inputs. This section describes the requirements associated with the audio feeds to the transmitter. All connections are made at the rear of the transmitter (see Figure 7-1 on page 7-5). Where D-sub connectors are used as the interface, Nautel provides an associated mating connector in the ancillary parts kit to facilitate customer connections.

- [Analog inputs](#)
 - [Left and right inputs](#)
 - [SCA generator input - see page 7-2](#)
 - [MPX input - see page 7-2](#)
 - [MPX SCA/RDS inputs - see page 7-2](#)
- [Digital inputs - see page 7-3](#)
 - [AES/EBU - see page 7-3](#)
 - [RDS/RBDS generator input - see page 7-3](#)
 - [Carrier frequency and pilot phase control - see page 7-3](#)
 - [Pilot sample output - see page 7-3](#)

ANALOG INPUTS

The VS300 accepts the following analog inputs:

LEFT AND RIGHT INPUTS

An analog left/right or monaural input (left only) (30 Hz to 15 kHz, 0 -12 dBm) can be applied to **ANALOG AUDIO/SCA3/1PPS** 9-pin, male D-sub connector A1J5B [left (+ on pin 4, - on pin 8), right (+ on pin 2, - on pin 7) and shield on pin 3]. The VS300's front panel AUI allows for configuration of the audio input mode (left, right or stereo). Provision is made for adjustment of the input sensitivity and pre-emphasis. The input impedance for each input is 600 Ω .

**NOTE:**

Transmitters are factory configured to provide 100% modulation (± 75 kHz) with an analog L/R input level of precisely 1.24 V rms (4.7 dBu).

The analog left and SCA generator 1 inputs use the same connection point and cannot be used at the same time. Similarly, the analog right and SCA generator 2 inputs use the same connection point and cannot be used at the same time.

SCA GENERATOR INPUT

Dual internal SCA generators can be interfaced via the **ANALOG AUDIO/SCA3/IPPS** 9-pin male D-sub connector (A1J5B) [SCA1 (+ on pin 4, - on pin 8), SCA2 (+ on pin 2, - on pin 7) and shield on pin 3]. The input impedance is 600 Ω and the adjustment range is 0 to +12 dBu.



NOTE:

Transmitters are factory set for a 1.24 V rms (4.7 dBu) SCA generator input level.

The SCA generator 1 and analog left inputs use the same connection point and cannot be used at the same time. Similarly, the SCA generator 2 and analog right inputs use the same connection point and cannot be used at the same time.

MPX INPUT

Balanced and unbalanced wideband MPX (composite) inputs (30 Hz to 100 kHz) are provided on the **MPX BAL/UNBAL IN** female BNC connector (A1J7). The **UNBAL/BAL** jumper (A1E1) inside the transmitter allows selection between balanced (jumper installed between pins 2 and 3) and unbalanced (jumper installed between pins 1 and 2) mode. The default setting is balanced. The levels are nominally 3.5 V pk-pk for ± 75 kHz carrier deviation, and are adjustable between 0.5 V and 5 V pk-pk. The input impedance is 1200 Ω .



NOTE:

Transmitters are factory configured to provide 100% modulation (± 75 kHz) with a wideband composite input level of precisely 1.24 V rms (3.5 V pk-pk).

MPX SCA/RDS INPUTS

Two unbalanced inputs (20 kHz to 100 kHz) are provided on the **SCA1 IN** (A1J6A) and **SCA2/RDS IN** (A1J6B) female BNC connectors, which accept pre-modulated SCA information. The levels are nominally 2.8 V pk-pk for ± 75 kHz carrier deviation, and are adjustable between 0.5 V and 5 V pk-pk. The input impedance for each input is 10 k Ω . A third MPX SCA input can be applied to **ANALOG AUDIO/SCA3/IPPS** 9-pin male D-sub connector A1J5B (pins 1 and 9).



NOTE:

Transmitters are factory configured to provide 10% modulation (± 7.5 kHz) with an SCA input level of precisely 1.0 V rms (2.8 V pk-pk).

DIGITAL INPUTS

The VS300 accepts the following digital inputs:

AES/EBU

The VS300 accepts AES/EBU digital audio via the **AES/EBU IN** 3-pin female XLR connector (A1J3) (110 Ω balanced; supports sample rates between 20 and 192 kHz). The VS300's UI allows for configuration of the audio input mode (left, right or stereo) and level (in dBFS).

RDS/RBDS GENERATOR INPUT

The VS300 accepts ASCII or UECP data for its internal RBDS/RDS generator via RS-232 on the **RDS/RBDS IN** 9-pin female D-type connector (A1J5A). The data is framed and modulated on a 57 kHz sub-carrier, which forms part of the composite signal.



NOTE:

The VS300 also supports stand-alone RDS/RBDS operation. In this mode, RDS/RBDS parameters are configured through the AUI.

CARRIER FREQUENCY AND PILOT PHASE CONTROL

The VS300 provides carrier frequency and pilot phase control from a precision GPS reference on the **10MHz IN** female BNC connector (A1J4B) (between 0.5 V and 2 V pk-pk sine wave input; 50 Ω) and 1PPS on the **ANALOG AUDIO/SCA3/1PPS** 9-pin male D-sub connector (A1J5B, pins 5 and 6; 5 V TTL input level, 10 k Ω).

PILOT SAMPLE OUTPUT

The VS300 provides a 19 kHz pilot sample (500 mV pk-pk) on the **PILOT SAMPLE OUT** female BNC connector (A1J4A).

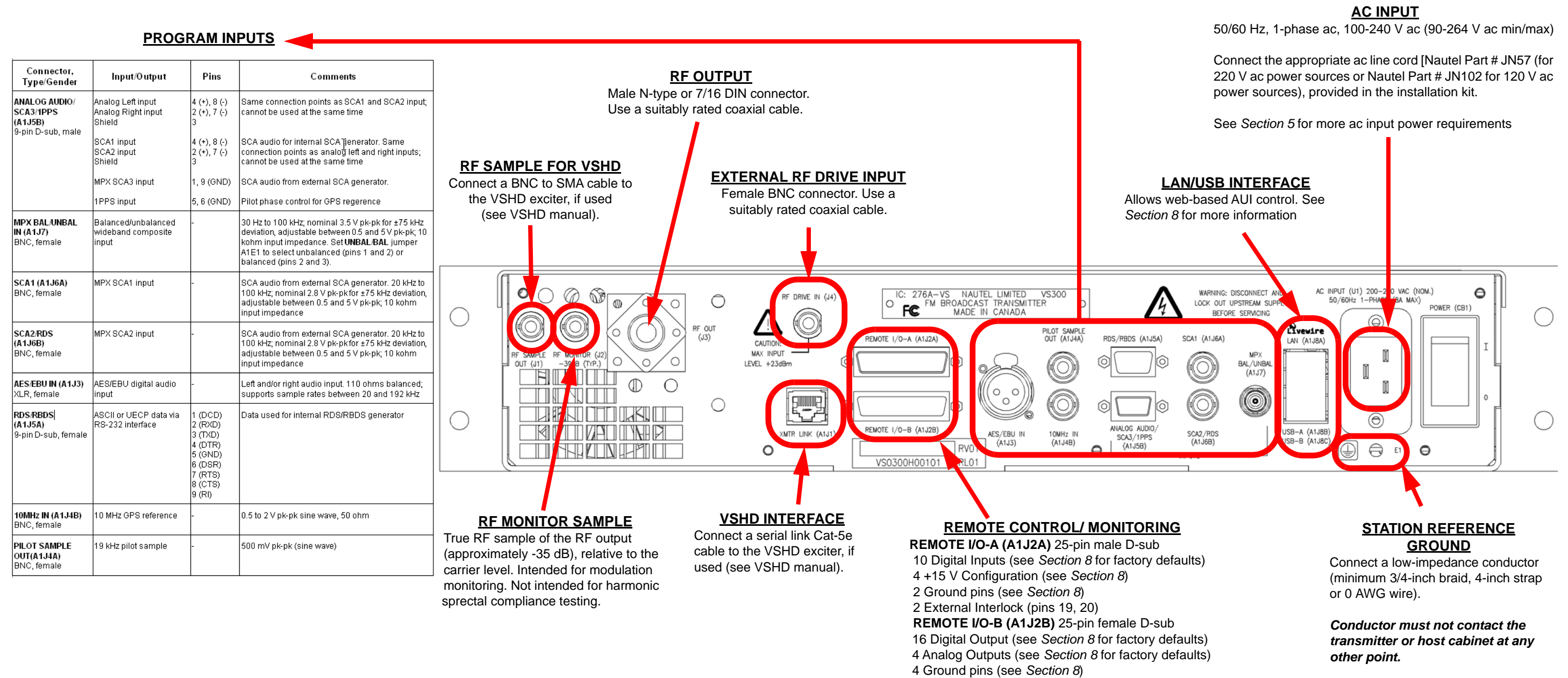

Figure 7-1: VS300 Rear Panel Connections

SECTION 8: PLANNING FOR CONTROL AND MONITORING

This section describes the options for controlling and monitoring the VS300 transmitter. All connections are made at the rear of the transmitter (see Figure 7-1 on page 7-5). Consider the following information and plan for the necessary requirements (wiring, remote switches/ indicators, LAN, etc.):

- [Front panel UI control](#)
- [Remote inputs - see page 8-2](#)
- [Remote outputs - see page 8-6](#)
- [Analog outputs - see page 8-9](#)
- [Web based AUI control - see page 8-10](#)
- [SNMP Control/Monitoring - see page 8-11](#)
- [Nautel Phone Home - see page 8-12](#)
- [External interlock - see page 8-12](#)

FRONT PANEL UI CONTROL

The VS300's front panel user-interface (UI) lets you locally control a number of transmitter functions and set parameters.

For detailed information about the front panel UI, refer to the *VS300 Operating and Maintenance Manual*. In addition, the front panel UI lets you define and control the on/off status, the preset RF power level, and the system alarm reset remotely using a conventional remote control interface (see [“Remote inputs” on page 8-2](#) and [“Remote outputs” on page 8-6](#)) or a LAN (see [“Web based AUI control” on page 8-10](#)).

REMOTE INPUTS

You can connect to ten remote inputs, which allow you to remotely control various operational characteristics of the transmitter. Each input is mapped to a control that is preset at Nautel, but is also user-configurable.

See [Table 8.1 on page 8-5](#) for a list of the factory default selections for remote inputs 1 through 10, their associated pin on the **REMOTE I/O-A** 25-pin male D-sub connector (A1J2A) at the rear of the transmitter, and their functional descriptions.

Refer to the *VS300 Operations and Maintenance Manual* for instructions on changing the remote input settings.

Unless otherwise noted, these inputs are only accepted by the transmitter if the remote/local status is set to remote enabled (local plus remote). That setting can only be made by a local user using the front panel UI. All inputs are active when a ground (0 V) is applied.

The external remote input circuits interface with the transmitter via the **REMOTE I/O-A** 25-pin male D-sub connector (A1J2A) and then with opto-couplers on the control/exciter PWB (A1). The opto-couplers buffer and isolate the external circuits and prevent any unwanted transients from affecting the transmitter.

Nautel provides the appropriate gender of mating connector (Nautel Part # JS28) and connector shell (Nautel Part # JS35) in the ancillary parts kit to facilitate customer connections to the rear panel D-sub connector.

EXTERNAL SWITCHING CIRCUIT REQUIREMENTS

The switching circuits for the remotely controlled functions must be the equivalent of a normally open (momentary) switch. The switches must be configured to operate as a single-ended input using the transmitter's 15 V dc as the source [see “[Option 1 - Single Ended Input \(Internal dc supply\)](#)” on page 8-3] or as a differential input using an external dc power supply (12 - 18 V) [see “[Option 2 - Differential Input \(External dc supply\)](#)” on page 8-3] applied to A1J2A-9 and A1J2A-21.

NOTE: *The selected configuration applies to all remote inputs; inputs cannot be configured separately.*

Inputs are activated by an active pulse unless otherwise noted. To ensure proper operation, the duration of the active pulse should be a minimum of 250 ms. See [Table 8.1 on page 8-5](#) for the various logic control options for remote inputs.

OPTION 1 - SINGLE ENDED INPUT (INTERNAL DC SUPPLY). If you plan to use the transmitter's internal 15 V supply as the source for the remote inputs (1 through 10), connect pins A1J2A-10 and A1J2A-22 to pins A1J2A-9 and A1J2A-21 respectively as shown in [Figure 8.1 on page 8-3](#).

When the remote input is configured for ‘falling edge’ or ‘active low’ logic, a logic low command (current-sink-to-ground) must be applied to the appropriate remote input (1 through 10). To avoid a ground loop, obtain the ground from the appropriate pin of A1J2A (pin 19 or 23). When the remote input is configured for ‘rising edge’ or ‘active high’ logic, a logic high command (open circuit) must be applied to the appropriate remote input (1 through 10).

Figure 8.1: Single-Ended Input Selected

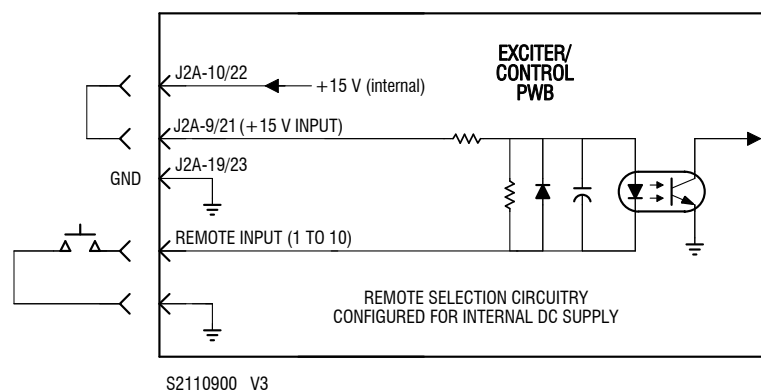

NOTE: The selected configuration is determined by the connections to pins J2A-9, 10, 21 and 22 and applies to all remote inputs (1 through 10). They cannot be configured separately.

The momentary switch should be located between a ground source on the exciter/control PWB and the remote input.

OPTION 2 - DIFFERENTIAL INPUT (EXTERNAL DC SUPPLY). If you plan to use an external dc voltage (12 V to 18 V) as the source for the remote inputs, the connections to the **REMOTE I/O-A** connector (A1J2A) are shown in [Figure 8.2](#).

When the remote input is configured for 'falling edge' or 'active low' logic (default), dc voltage must be applied between A1J2A-9/21 and the appropriate remote input (1 through 10). When the remote input is configured for 'rising edge' or 'active high' logic, an open circuit (no dc voltage) must be applied to the appropriate remote input (1 through 10).

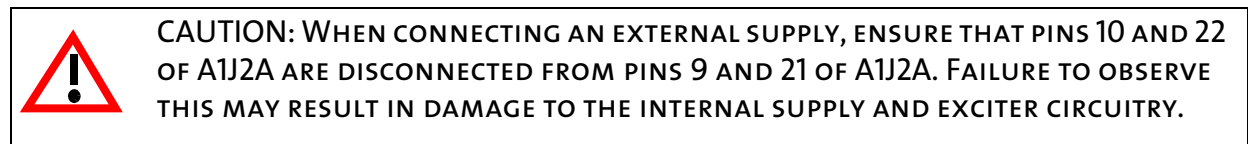
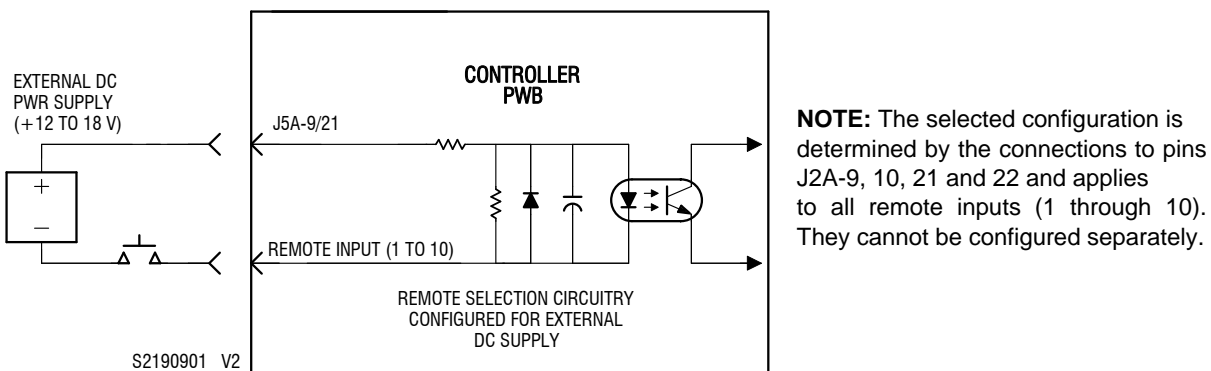

Figure 8.2: Differential Input Selected



The momentary switch should be located between the dc supply's negative output and the remote input.

REMOTE INPUT CONNECTIONS

Remote inputs 1 through 10, as required, connect to the pins of REMOTE I/O-A 25-pin male D-sub connector A1J2A on the rear of the transmitter. See [Table 8.1 on page 8-5](#) to determine the input pin associated with each remote input, the default remote inputs and their functions.

Table 8.1: Factory Defined (Default) Remote Inputs

Remote Input #	A1J2A Pin	Default Remote Input (Channel)	Function (based on default channel)
1	7	RF On	Same as pressing the UI RF On button. Tells the transmitter to provide RF power if possible.
2	8	RF Off	Same as pressing the UI RF Off button. Tells the transmitter to disable RF power.
3	1	Reset	Causes a system reset.
4	14	Power Increase	Increases the power level of the current preset. Apply a momentary ground input to increase the power slightly, or apply a longer duration ground input to continue increasing power.
5	2	Power Decrease	Decreases the power level of the current preset. Apply a momentary ground input to decrease the power slightly, or apply a longer duration ground input to continue decreasing power.
6	15	Preset 1 Select	Selects preset 1 as active.
7	4	Not Assigned	Remote inputs 7 through 10 default to Not Assigned. If the remote input is not assigned to a particular channel, and a preset is created with the specific naming convention (e.g., Preset #), the input will automatically be assigned to that preset. If the preset name does not match the convention shown above, the preset will not automatically assign to the remote input. This only applies to remote inputs 7 through 10 for Presets 2 through 5, respectively. If selected as a Preset Select, it will function like Preset 1 Select shown above.
8	17	Not Assigned	
9	5	Not Assigned	
10	18	Not Assigned	

NOTES:

Default channels shown. Other Remote Input channel options are Force Host Reboot and Custom Input.

Default control logic for all remote inputs is Falling Edge.

REMOTE OUTPUTS

Up to 16 remote outputs, that indicate either the presence of various alarms or the status of operator controlled circuits, are available for remote monitoring on the **REMOTE I/O-B** 25-pin female D-sub connector (A1J2B) on the rear of the transmitter. The sources and active logic levels of these remote outputs are preset at Nautel, but are also user-configurable. See [Table 8.2 on page 8-7](#) for a list of the factory default remote outputs, their associated pins on the **REMOTE I/O-B** 25-pin female D-sub connector (A1J2B), their default logic (control) settings and their descriptions.

A switching device for each remote output, configurable through the front panel UI, provides the desired active logic when a true condition exists.

For example, if a remote output is configured as **Output Low When On** (see the *VS300 Operations and Maintenance Manual* for the specific text displayed on the UI), then the remote output's switching circuit will provide a current-sink-to-ground when a logic true (on) condition exists and an open collector for a logic false (off) condition.

If the remote output is configured as **Output Low When Off** (see the *VS300 Operations and Maintenance Manual* for the specific text displayed on the UI), then the remote output's switching circuit will provide an open collector when a logic true (on) condition exists and a current-sink-to-ground for a logic false (off) condition.

Each switching circuit must present impedance between the switching device and a dc voltage source that limits current flow to no more than 30 mA. Each circuit's positive voltage source must not exceed 30 V dc. The internal +15 V supply is capable of providing up to 125 mA, which should not be exceeded by the sum of all active status outputs. If you require more current capability, use an appropriate external power supply.

Nautel provides the appropriate gender of mating connector (Nautel Part # JS28) and connector shell (Nautel Part # JS35) in the ancillary parts kit to facilitate customer connections to the control interface PWB's D-sub connector, as applicable.

REMOTE OUTPUT CONNECTIONS

Remote outputs 1 through 16, as required, connect to terminals of **REMOTE I/O-B** 25-pin female D-sub connector A1J2B on the rear of the transmitter. See [Table 8.2 on page 8-7](#) to determine the output pin associated with each remote output. Ground/shield connections are available on A1J2B pins 5, 10, 15 and 20.

Table 8.2: Factory Defined (Default) Remote Outputs

Remote Output #	A1J2B Pin	Default Output (Channel)	Default Logic (Control)	Description (based on default channel)
1	1	RF On/Off Status	Output Low When RF On	Indicates the on/off status of the transmitter's RF power stage. By default, the output is low (current-sink-to-ground) when RF is on (enabled) and high (open collector) when RF is off (disabled). Alternate control setting: 'Output Low When RF Off'.
2	2	Remote Enabled Status	Output Low When Remote	Indicates the local/remote control status of the transmitter. Changes can only be made remotely if the transmitter's remote control is enabled. The local user's control of the transmitter is unaffected, without restriction. The output is low (current-sink-to-ground) when remote control is enabled and high (open collector) when remote control is disabled. Alternate control setting: 'Output Low When Local' (where remote control is disabled).
3	3	Overall Summary Alarm	Output Low When True	The output is low (current-sink-to-ground) when any alarm is occurring (true condition) and high (open collector) when there is no alarm (false condition). Alternate control setting: 'Output Low When False'.
4	4	External Interlock Open Alarm	Output Low When True	The output is low (current-sink-to-ground) when the RF output is inhibited because an external interlock switch has been opened (true condition) and high (open collector) when there is no alarm (false condition). Alternate control setting: 'Output Low When False'.
5	6	High Temperature Summary Alarm	Output Low When True	The output is low (current-sink-to-ground) when the power amplifier heatsink's temperature exceeds 80°C (176°F) OR if the power supply module experiences a temperature related fault OR the transmitter is operating at reduced power due to fan failure(s) (true condition) and high (open collector) when there is no alarm (false condition). Alternate control setting: 'Output Low When False'.
6	7	External Summary Alarm	Output Low When True	The output is low (current-sink-to-ground) when something external to the transmitter is in a fault condition (e.g., transmitter interlock, audio loss, etc.) (true condition) and high (open collector) when there is no alarm (false condition). Alternate control setting: 'Output Low When False'.
7	8	Forward Power Low Alarm	Output Low When True	The output is low (current-sink-to-ground) when the RF output power is below the user configurable threshold (default is 50%) (true condition) and high (open collector) when there is no alarm (false condition). Alternate control setting: 'Output Low When False'.

Remote Output #	A1J2B Pin	Default Output (Channel)	Default Logic (Control)	Description (based on default channel)
8	9	High Reflected Summary Alarm	Output Low When True	The output is low (current-sink-to-ground) when the peak reflected power is exceeding 8 W and/or the transmitter is in an SWR foldback, SWR shutback or SWR shutdown state (true condition) and high (open collector) when there is no alarm (false condition). Alternate control setting: 'Output Low When False'.
9	11	Power Amplifier Summary Alarm	Output Low When True	The output is low (current-sink-to-ground) when a fault is occurring that is related to the IPA or PA section of any RF power module (true condition) and high (open collector) when there is no alarm (false condition). Alternate control setting: 'Output Low When False'.
10	12	Power Supply Summary Alarm	Output Low When True	The output is low (current-sink-to-ground) when a power supply related fault (e.g., LVPS fault, fan/IPA supply fault, etc.) is occurring (true condition) and high (open collector) when there is no alarm (false condition). Alternate control setting: 'Output Low When False'.
11	13	AC Summary Alarm	Output Low When False	The output is low (current-sink-to-ground) when the ac input voltage is acceptable (false condition) and high (open collector) when the ac input voltage is outside the acceptable range (true condition). Alternate control setting: 'Output Low When True'.
12	14	Preset 1 Status	Output Low When Active	The output is low (current-sink-to-ground) when preset 1 is active and high (open collector) when preset 1 is inactive. Alternate control setting: 'Output Low When Inactive'.
13	16	Not Assigned	N/A	Remote outputs 13 through 16 default to Not Assigned. If the remote output is not assigned to a particular channel, and a preset is created with the specific naming convention (e.g., Preset #), the output will automatically be assigned to that preset status. If the preset name does not match the convention shown above, the preset status will not automatically assign to the remote output. This only applies to remote outputs 13 through 16 for Presets 2 through 5, respectively. If selected as a Preset Status, it will function like Preset 1 Status shown above.
14	17	Not Assigned	N/A	
15	18	Not Assigned	N/A	
16	19	Not Assigned	N/A	

NOTES:

Default channels shown. Many other options exist including most alarms, etc.

Typical control logic for remote outputs is Output Low When True.

ANALOG OUTPUTS

The transmitter provides sample signals that let you monitor performance. The sources of these analog outputs are pre-defined and configured at Nautel. See [Table 8.3 on page 8-9](#) for a list of these pre-defined outputs, their descriptions and their associated output pins on the **REMOTE I/O-B** 25-pin female D-sub connector (A1J2B). The outputs are op-amp buffered outputs from a digital-to-analog converter (DAC). The dc voltage of each output is between 0 to 6 V, and varies within the real limits of the parameter being monitored. The monitoring circuit's impedance for each analog output must be greater than 1,000 ohms.

ANALOG OUTPUT CONNECTIONS

Analog outputs 1 through 4 connect to pins of the **REMOTE I/O-B** 25-pin female D-sub connector (A1J2B) on the rear of the transmitter. See [Table 8.3](#) to determine the terminal associated with each analog output. A ground/shield connection is available on A1J2B, pin 25.

Table 8.3: Factory Defined Analog Outputs

Analog Output	Description	A1J2B Pin
1. Forward Power	Reports a sample of the transmitter's forward power. This dc voltage is a linear function and is full-scale (6 V) when the forward power is 400 W.	21
2. Reflected Power	Reports a sample of the transmitter's reflected power. This dc voltage is a linear function and is full-scale (6 V) when the reflected power is 40 W.	22
3. PA Voltage	Reports a sample of the PA voltage. This dc voltage is a linear function and is full-scale (6 V) when the PA voltage is 60 V.	23
4. Total PA Current	Reports a sample of the total dc current of the final RF power stage amplifiers. This dc voltage is a linear function and is full-scale (6 V) when the dc current is 15 A.	24

RF MONITOR SAMPLE

A true RF sample of the RF output voltage waveform is available for external monitoring on the **RF MONITOR** BNC connector (J2) on the rear panel of the transmitter. The coupler yields approximately -39dB (± 1.5 dB), relative to the carrier level, at the FM broadcast carrier frequency (88 - 108 MHz).

WEB BASED AUI CONTROL

An Ethernet port is available on the **LAN** connector (A1J8A) on the rear panel of the transmitter. This port allows a user with proper authentication to remotely control and interrogate the VS300's operational status. All functionality available on the front panel UI and more is available remotely, provided the user has been granted proper authorization (refer to the *VS300 Operations and Maintenance Manual* for details on setting user permissions). Nautel recommends you use shielded Cat5 Ethernet cable to make this connection.

REMOTE ACCESS

The only access to the AUI is through the **LAN** connector on the rear panel on the transmitter.

For security purposes, Nautel recommends you place your transmitter behind a router acting as a firewall. To allow remote AUI access to a transmitter behind a firewall, the firewall must allow TCP traffic through the following ports:

- TCP port 80: required to allow the web browser operating on the remote computer to access the web server operating on the transmitter.
- TCP port 3501: used for regular AUI-to-transmitter communication.
- TCP port 7005: Used for RDS/RBDS communication.
- TCP ports 161 and 162: Used for Agents and Traps SNMP, respectively.
- UDP port 123: Used as the NTP port for time synchronization.

For security purposes, Nautel recommends you block the following port:

- TCP port 22: block during normal operation; when required, may be used to allow Secure Shell (SSH) programs such as PuTTY, etc. to access the transmitter.

Once your transmitter is isolated behind a firewall, there are a variety of standard network management techniques that can be used to establish a connection, including routing tables and a virtual private network (VPN).

Detailed information about network management is beyond the scope of this manual. Selecting a specific technique often depends on your existing network configuration. Nautel recommends that the planning, implementation and ongoing support of a network that includes a transmitter be undertaken by a team that includes at least one member with suitable knowledge of network management.



Note:

If you have more than one transmitter on the same LAN, you will need to use port forwarding to allow access to individual transmitters on the network.

SNMP CONTROL/MONITORING

SNMP (Simple Network Management Protocol) is a request-response protocol where the client and agent communicate using binary packets. For Nautel transmitters, SNMP is used to communicate transmitter control commands (e.g., RF on/off, active preset, power adjustments, etc.) as well as monitor data such as alarm states and meter values. Although there are multiple versions of the protocol in widespread use, Nautel only supports SNMPv1 and SNMPv2, and traps are only supported for SNMPv1.

Nautel provides the central software component, the SNMP agent, which is a program that runs on the transmitter. The SNMP agent interacts with SNMP client software applications, which range from simple MIB browser applications like the free one provided by iReasoning to customized solutions such as those provided by Burk. Nautel does not provide SNMP client software.

Access to SNMP control/monitoring is through the RJ45 LAN port (A1J8A) on the rear panel of the transmitter. When you log into the remote AUI, you can access the **User Settings -> SNMP Configuration** page to set the SNMP Agent Port number, Read Community and Write Community passwords and SNMP Trap information.

If you are planning to use SNMP, contact Nautel to obtain MIB files for your client software.

MIB files are available through Nautel's FTP site: ftp://www3.nautel.com/SNMP_MIBs/

EMAIL SERVER

The transmitter's remote AUI allows you to configure an email notification feature, which can initiate emails to specified users when specific alarm or status conditions occur (refer to the *VS300 Operations and Maintenance Manual* for details).

The transmitter's email service expects to be connected to an unsecure email server (i.e., not requiring a password to gain access). If you plan to use the email notification feature, make sure you have a secure network for your email server and the transmitter.

NAUTEL PHONE HOME

Phone Home is a system developed by Nautel that takes advantage of the vast amount of data collected by Nautel transmitters by pro-actively sending information to Nautel via the Internet once a user enables Phone Home on their transmitter.

This data includes logs, alarms and meter readings which are then stored in a database and can be analyzed by Nautel Customer Service if an alarm is reported by the transmitter. Since all data is pushed out to Nautel by the transmitter, there is no need to reconfigure your firewall and potentially compromise your transmitters security. All data transfers are one way.

Nautel transmitters are intelligent, collecting data on nearly every aspect affecting your transmitter's performance. When this data is used by Nautel Customer Service staff for diagnostic purposes it cuts down on repair time and gets you back on air faster.

Nautel Customer Service technicians can use Phone Home to analyze data in real time, even accessing the live AUI, or to view the state of a customer's transmitter at any time leading up to a fault.

This unique diagnostic approach allows Nautel support staff to review the events leading up to and during an alarm occurrence, giving customer service technicians valuable insight into how your transmitter is behaving before, during and after an alarm and how this behavior may be related to the alarm event.

If you are planning to participate in the Nautel Phone Home feature, no pre-installation actions are required. After successfully installing your VS300 and connecting to the remote AUI, navigate to the **User Settings -> Nautel Phone Home** page and enter your serial number and email (optional). Nautel will begin to monitor your transmitter's performance.

EXTERNAL INTERLOCK

An external safety interlock is available between pins 19 and 20 on the **REMOTE I/O-A** 25-pin male D-sub connector (A1J2A) on the rear panel of the transmitter. This connection allows you to connect an external safety interlock circuit that provides an emergency RF inhibit control for the VS300. It must present a short circuit (low impedance) between the terminals when the interlock circuit is intact and it is safe to enable the RF output. It must present an open circuit when any interlock switch is activated and the RF output should be inhibited. You can install any number of serial interlock switches.

SECTION 9: PARTS AND TOOLS

This section describes parts associated with the VS300 transmitter, and tools needed during installation and routine operation. Topics include:

- [Parts supplied by Nautel - see page 9-2](#)
- [Parts not supplied by Nautel - see page 9-2](#)
- [Parts ordering - see page 9-2](#)
- [Module replacement program - see page 9-3](#)
- [Tools for installation - see page 9-3](#)

CONTACTING NAUTEL

You can reach Nautel to order parts or for technical assistance at:

Nautel Limited

10089 Peggy's Cove Road

Hackett's Cove, NS Canada B3Z 3J4

Phone: +1.877.628.8353 (Canada/US)

+1.902.823.5100 (International) Fax: +1.902.823.3183

Email: support@nautel.com

Web: www.nautel.com

PARTS SUPPLIED BY NAUTEL

INSTALLATION KIT

An installation kit is shipped with the VS300. This kit contains items needed during the installation process. The kit includes toroids, an interlock jumper, ac power cord, and miscellaneous transmitter mounting hardware.

ANCILLARY PARTS KIT

An ancillary parts kit is shipped with the VS300. This kit contains items that may be needed for future maintenance. The kit includes a spare battery, spare fuses, D-sub mating connectors, miscellaneous hardware, tyrap and some installation tools.

DOCUMENTATION

See [“VS300 transmitter manuals”](#) on page xii.

PARTS NOT SUPPLIED BY NAUTEL

Some parts and materials required to complete installation are not supplied by Nautel. The parts you need vary with the installation requirements. The list of parts you normally provide yourself during installation include:

- A suitable 50 Ω RF output coaxial cable, terminated by the proper connector, complete with center male connector at the transmitter end.
 - All external control and monitor wiring, including the associated terminating devices, conduit and conduit clamps.
 - All electrical power cables, including conduit, terminating devices, and conduit clamps.
-

PARTS ORDERING

You can order replacement parts from your Nautel sales agent, or directly from Nautel through the Nautel website.

MODULE REPLACEMENT PROGRAM

Nautel offers a module replacement program for customers who require expedited servicing and replacement of faulty modules. The module replacement program provides immediate replacement of failed modules with refurbished modules.

- The replacement module is shipped to the customer as soon as the customer reports the failure. The customer then returns the failed module to Nautel using the same shipping package.
-

TOOLS FOR INSTALLATION

The tools you need during transmitter installation include the following:

- Philips screwdrivers, size #2 (suitable for M5 hardware)
- 8 mm nut driver (suitable for M5 hardware)
- Pliers
- Wire cutters
- Electrician's knife

SECTION 10: PRE-INSTALLATION ASSISTANCE

Nautel provides a number of support options to help you during pre-installation planning and preparation:

- [Pre-installation consulting](#)
- [Installation and commissioning service](#)
- [Online documentation - see page 10-3](#)
- [On-site support - see page 10-3](#)
- [Training - see page 10-3](#)
- [Extended warranties - see page 10-4](#)

PRE-INSTALLATION CONSULTING

Nautel field support specialists are available to answer questions and work with you to ensure that your site will be ready for the installation of your VS300 transmitter. For support, contact Nautel Customer Service and request assistance (see [“On-site support” on page 10-3](#)).

INSTALLATION AND COMMISSIONING SERVICE

Nautel offers an installation and commissioning service to customers who want assistance with configuring and commissioning a new Nautel transmitter. After the customer completes the transmitter assembly and installation, Nautel technical personnel will spend up to three days on-site to help make the ac power, RF and remote connections, and to assist with the configuration and testing of Nautel equipment.

The customer is responsible for ensuring that the following stages of installation have been completed, prior to the arrival of Nautel personnel:

- The transmitter has been unpacked, closely checked for any damage caused by shipping, and then assembled.

- Ac power wiring for the transmitter has been installed and connected at the breaker panel or the building's service entrance.
If local electrical codes allow Nautel personnel to connect the transmitter to the ac supply, using the customer's cable, that task is included in this service. Otherwise, the customer must ensure that an approved electrician is present for this task.
- The customer has prepared the RF coaxial cable – used to connect the transmitter to the antenna – and installed the required connector. The customer has also installed the RF coaxial cable in place and connected it to the antenna, while leaving the transmitter end of the cable unconnected.
- Where required, all remote control and monitoring cables have been installed and connected to the station equipment (e.g., modulation monitor, frequency monitor, and power meter).
- The site has been made ready for the equipment, and adequate protection against lightning and lightning-induced transients has been provided.
- The following test equipment has been made available at the site:
 - Two-channel oscilloscope (with probes)
 - Audio signal generator
 - Distortion analyzer
 - Modulation monitor
 - Frequency counter
 - 50 Ω test load (rated for 150% of carrier power, VSWR less than 1.1:1)

Nautel's service representative takes full responsibility for commissioning the transmitter, validating all external interfaces (i.e., the ac supply, RF output, remote control and monitoring equipment) and checking out the equipment prior to activation. The service representative turns on the transmitter, performs all adjustments and set-up procedures, and carries out *proof of performance* tests at the site. These tests ensure that the transmitter is operating normally in compliance with its specifications. The service representative also provides a demonstration and a short explanation of the operation of the transmitter. Finally, the customer signs an *Acceptance of Installation Certificate* that provides feedback to Nautel regarding the commissioning service.

ONLINE DOCUMENTATION

Nautel provides documentation online to customers, letting you familiarize yourself with specifications, operation, maintenance and troubleshooting prior to the delivery of your equipment.

- Documentation is provided on CD-ROM or USB device that is delivered with the transmitter and is also available in paper binders.
-

ON-SITE SUPPORT

If you require on-site assistance, Nautel's field support specialists can help you prepare your site, and ensure that your VS300 transmitter installation can proceed as quickly as possible. For more information about on-site support, including scheduling and pricing, contact Nautel Customer Service:

- Telephone: +1.902.823.5100
- Fax: +1.902.823.3183
- Email: support@nautel.com

After business hours (Atlantic time or Eastern time in North America), requests sent by fax or email will be acknowledged within one working day.

TRAINING

Nautel's SBE-certified broadcast training programs satisfy your day-to-day knowledge requirements. Students participating in Nautel's broadcast transmitter or RF basics training programs earn one SBE credit for each completed day of training. Nautel's comprehensive selection of training programs will help a customer's staff develop valuable skill sets, reduce downtime, and make the most of the customer's technology investment.

Nautel training programs are made up of individual modules that can be *mixed and matched* to meet the customer's specific training needs. All Nautel training courses are available at the Nautel Training Center. Training can also be provided at the customer's facility, for training the customer's technical staff on the customer's transmitter.

All Nautel training courses combine classroom and hands-on laboratory work to ensure a balanced learning experience. Many of our classes also include diagnostic lab exercises.

Nautel training courses feature:

- Limited class sizes to ensure maximum student participation and access to equipment
- Emphasis on need-to-know, day-to-day knowledge
- Labs that focus on the tasks most often performed at the transmitter site

VS SERIES ON-SITE OR FACTORY TRAINING

This includes product overview, site and pre-installation, theory of operation, testing and adjustments, operating instructions, system-level troubleshooting, component-level troubleshooting, component parts lists, and wiring route sheets.

EXTENDED WARRANTIES

Nautel's standard four-year warranty provides excellent coverage and satisfies most customers' needs. However, if you want extended coverage, Nautel offers one- and two-year Extended Warranty Plans to cover electrical and mechanical repairs or replacements for all Nautel equipment.

COVERAGE

The Extended Warranty Plan includes:

- A module exchange program for many common modules and circuit boards (North America only)
- Toll-free hotline (North America only)
- Necessary labor performed by Nautel authorized personnel to repair the product to meet factory specifications
- Necessary components
- Modifications to correct performance problems
- Return shipping

DETAILS

Extended Warranty Plans must be purchased prior to the expiration of original four-year warranty.

One-year Extended Warranty Plans add an additional year (12 months) of coverage after the end of the customer's standard four-year warranty. The two-year plan adds an additional two years (24 months).

Only repairs done at Nautel's facilities or by Nautel authorized personnel will be covered by the Extended Warranty Plans.

You must ship faulty products back to Nautel, prepaid, and in the original package or in a package that provides equivalent protection.

Nautel can choose to repair or replace equipment.

PURCHASING A ONE- OR TWO-YEAR EXTENDED WARRANTY PLAN

If the transmitter is still covered by its original four-year warranty period, you can contact Nautel by telephone, fax, mail, or email with the model number, serial number and date of purchase.

Once you purchase a Nautel Extended Warranty Plan, you receive an extended warranty plan certificate, plan number, and a toll-free number (North America only) to call for any service-related issues.

USING THE EXTENDED WARRANTY PLAN

Contact Nautel's Canadian or U.S. service facility by phone, fax, or email as soon as a problem occurs. The following will be required when contacting Nautel:

- Extended warranty plan number
- Product model number
- Serial number
- Brief description of the problem

If Nautel's service technicians are unable to solve the problem over the telephone, Nautel will give you an RMA number. You then return the module or circuit board to a Nautel service facility, so that Nautel can provide a replacement. *Do not ship a component back to Nautel until you have an RMA number.*

SECTION 11: LIST OF TERMS

This section defines some of the terms that are used in Nautel documentation.

AES-EBU. Audio Engineering Society/European Broadcasting Union (AES/EBU) is the name of a digital audio transfer standard. The AES/EBU digital interface is usually implemented using 3-pin XLR connectors (the same type connector used in professional microphones). One cable carries both left-channel and right-channel audio data to the receiving device.

ARM. Advanced RISC (Reduced Instruction Set Computer) Machine. The specific ARM used in VS transmitters is ARM926, and is used for remote AUI functionality.

AUI. The Advanced User Interface is the web interface that allows for extensive control and monitoring of the transmitter.

CUTBACK. A reduction in RF output power, caused by the occurrence of multiple shutbacks within a pre-defined period.

CYCLING AC POWER. Turning off (disabling), then turning on (enabling) the ac power source.

DHCP. Dynamic Host Carrier Protocol.

DSP. Digital Signal Processing. Used for transmitter control and signal processing.

EEPROM. Electrically Erasable Programmable Read-Only Memory.

FOLDBACK. A reduction in RF output power, caused by adverse load conditions (high VSWR). No shutbacks or cutbacks have occurred.

INTERMEDIATE POWER AMPLIFIER (IPA). Refers to circuitry within the transmitter that amplifies the exciter's RF output to a level sufficient to drive the final RF amplifiers.

LATCHING ALARM. An alarm that, while active, keeps the transmitter in an 'RF inhibited' state. This type of alarm (e.g., High SWR Shutdown) require a reset - via the front panel or remote AUI - to attempt to restore transmitter operation.

LED. Light Emitting Diode (also referred to as lamp).

LUT. Look-Up Table.

MPX. Refers to the multiplexed baseband signal. Also referred to as the composite signal.

PRESET. A setting that controls power level, frequency and audio parameters. The VS300 allows you to pre-program multiple presets.

PWB. Printed Wiring Board.

SHUTBACK. A complete, but temporary loss of RF output power, caused by any one of a variety of faults, including high VSWR, high reject load power, RF drive failure, or an open external interlock.

SHUTDOWN. A complete and permanent loss of RF output power. Typically follows repeated cutback, foldback or shutback events.

SPI. Serial Peripheral Interface. A synchronous serial data link standard that operates in full duplex mode. Devices communicate in master/slave mode where the master device initiates the data frame. Multiple slave devices are allowed with individual slave select (chip select) lines. Also referred to as a "four wire" serial bus.

SURGE PROTECTION PANEL. An electrical panel that protects equipment from electrical surges in the ac power supply, antenna or site ground caused by lightning strikes.

VSWR. Voltage standing wave ratio. This is an expression of the ratio of forward voltage to reverse voltage on the feedline and antenna system. An ideal VSWR of 1:1 provides maximum transmitter-antenna efficiency.

VS300 PRE-INSTALLATION MANUAL

Document: NHB-VS300-PRE

Issue: 9.0 2018-10-29

Nautel Limited

10089 Peggy's Cove Road
Hackett's Cove, NS Canada B3Z 3J4

Toll Free: +1.877.6NAUTEL (662.8835)
(Canada & USA only) or

Phone: +1.902.823.3900 or

Fax: +1.902.823.3183

Nautel Inc.

201 Target Industrial Circle
Bangor, Maine USA 04401

Phone: +1.207.947.8200

Fax: +1.207.947.3693

Customer Service (24-hour support)

+1.877.628.8353 (Canada & USA only)

+1.902.823.5100 (International)

Email: support@nautel.com

Web: www.nautel.com

© Copyright 2018 NAUTEL. All rights reserved.

